

# Solid-State Transformer (SST)

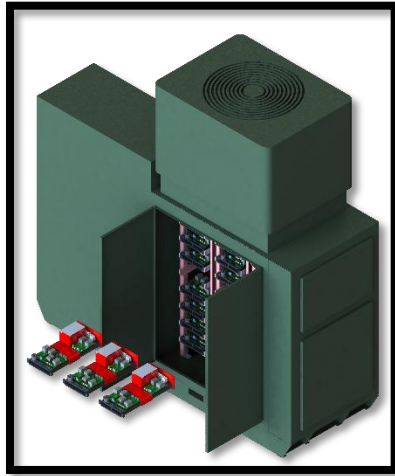

## Applications

AI data centers

EV fast-charging solutions

Energy storage, renewable integration, and grid modernization

## Technical Specifications

Parameter	Specification		
	1.25MW Current	Future 3MW	Future 7.5MW
<b>Transformer Power Rating</b>			
<b>Input Voltage</b>	11-13.8 kVAC, three-phase, 3 wire, 75kV BIL	11-13.8 kVAC, three-phase, 3 wire, 75kV BIL	12.0kVAC to 34.5kVAC, three-phase, 3 wire, 75-200kV BIL
<b>Output Voltage</b>	1,500 VDC, 380VDC and +/-400VDC optional	1,500 VDC, +/-400VDC optional	1500VDC, +/-400VDC optional
<b>Efficiency</b>	Greater than 98.5% at 50-100% load		
<b>Power Factor</b>	Unity (1.0), static VAR capability available		
<b>Harmonic Distortion</b>	<1% single harmonic, <3% total		
<b>Input Frequency</b>	50/60 Hz		
<b>Topology</b>	Cascade type, multilevel PWM on input		
<b>Parallel Operation</b>	3-5% droop enforces current sharing		
<b>Isolation</b>	Galvanic isolation with leakage monitoring	Galvanic isolation with leakage monitoring	Galvanic isolation w/ hi-resistance ground
<b>Cooling</b>	Forced air cooling, air circuit isolated	Forced air cooling, air circuit isolated	Immersion cooling
<b>Safety</b>	No combustible liquids	No combustible liquids	Envirotemp FR-3
<b>Reliability</b>	MTBF over 50,000 hours; modularity allows for low MTTR and high fault tolerance		
<b>Temperature</b>	-20°C to +50°C		
<b>Dimensions</b>	3.4m L x 1.4m D x 3.4m H	4.2m L x 1.4m D x 3.4m H	4.0m L x 1.7m D x 2.5m H
<b>Weight</b>	1800kg	2300kg	5000kg

## Protection and Communication

- Protection: Overvoltage, Overcurrent, Short Circuit, Thermal Protection, Fault Isolation, Grid fault ride-through
- Control Interfaces: Modbus over TCP/IP, CAN

## Key Benefits

- Footprint & Weight: Achieves a reduction of 50–70% in physical size and uses 50% less iron and copper compared to conventional solutions.
- Efficiency: Delivers grid to 12 VDC Load efficiency greater than 87% (versus 70% for conventional transformers).
- Cost: Reduces overall cost by 30% compared to conventional options; enables rapid deployment (6 months vs. 12 months).
- Design: Removes AC stages and allows for medium-voltage DC (MVDC) deployment.
- Reliability: Features N+1 redundancy and a low mean-time-to-repair (MTTR) due to its modular structure.
- Integration: Offers multi-port outputs (400–1,500 VDC), supports vehicle-to-grid (V2G) and renewable integration.
- Input Power Quality: Maintains less than 1% total harmonic distortion (THD), unity power factor, and provides enhanced grid support.

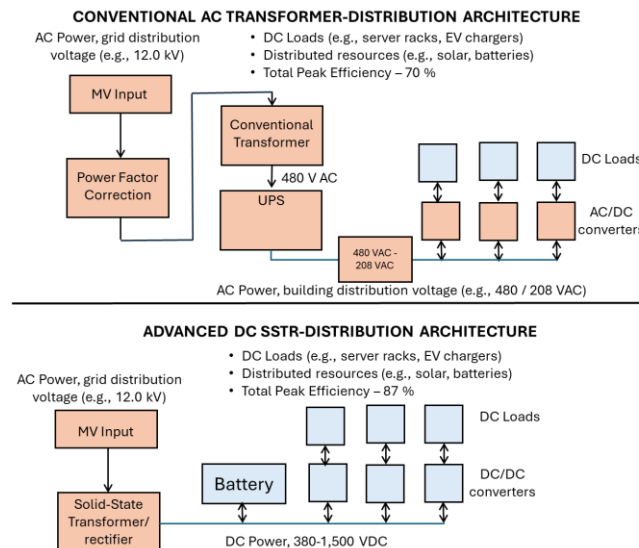

## Certifications and Standards

- Compliant with IEEE P3105, UL, ENERGY STAR, LEED, IEC, DOE standards
- Compatible with RE100 and net-zero initiatives



2415 Auto Park Way, Escondido, CA, 92029  
Phone: (760) 888-6899  
www.rocketruck.com